

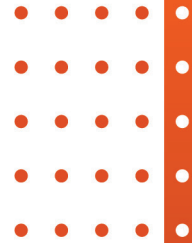

Tube Fittings



MAFFS VALVES & FITTINGS PVT LTD

Manufacturer of Industrial Valves, Instrumentation Valves & Fittings

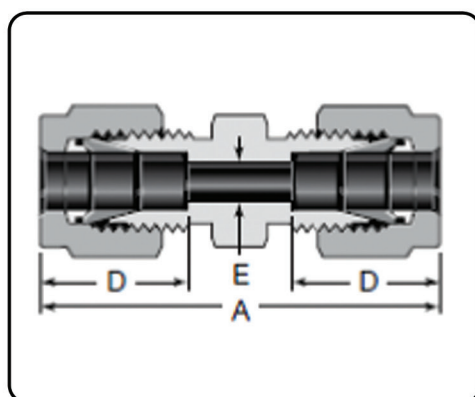

Tube OD in	Dimensions mm		
	A	D	E
1/16	25.10	8.60	1.30
1/8	35.60	12.70	2.30
3/16	37.30	13.70	3.00
1/4	40.90	15.20	4.80
5/16	42.90	16.30	6.40
3/8	45.00	16.80	7.10
1/2	51.30	22.90	10.40
1/2	109.20	—	12.70
5/8	52.10	24.40	
3/4	53.60		15.70
7/8	55.10	25.90	18.30
1	64.80	31.20	22.40
1 1/8			24.60
1 1/4	92.20	41.10	27.70
1 1/2	108.00	50.00	34.00
2	149.40	67.60	46.00

Tube OD	Dimensions mm		
	A	D	E
2	35.6	12.9	1.7
3	35.3		2.4
4	37.3	13.7	4.8
6	41.0	15.3	6.4
8	43.2	16.2	7.9
10	46.2	17.2	9.5
12	51.2	22.8	11.1
14	52.0	24.4	11.9
15			12.7
16			15.1
18	53.5	26.0	15.9
20	55.0	31.3	18.3
22			21.8
25	65.0	36.6	24.6
28	85.0	31.6	26.2
	65.4	42.0	28.6
30	92.7	49.4	33.7
32	97.3	65.0	45.2
38	114		
50	146		



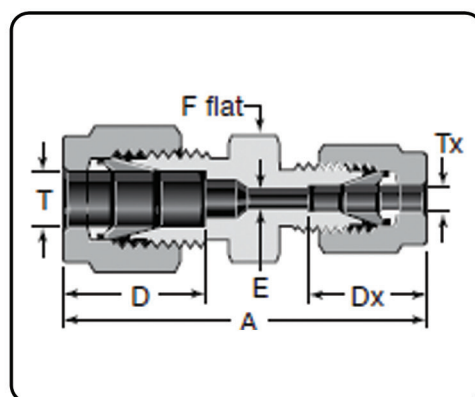

Tube OD		Dimensions mm					
T	Tx in	A	D	Dx	E	F	
2	1/8	35.2	12.9	12.8	1.7	12	
	1/4	38.6		15.3		14	
3	1/8	35.2	12.9	12.8	2.4	12	
	1/4	36.5		13.7		14	
4	1/16	34.3	15.3	8.6	4.8	14	
	1/8	38.5		12.8		14	
	1/4	41.0		15.3		14	
	5/16	42.3		16.2		14	
	3/8	43.2		16.8		16	
8	1/4	42.3	16.2	15.3	4.8	15	
	3/8	44.3		16.9		16	
10	1/8	41.8	17.2	12.8	2.4	18	
	1/4	44.5		15.3			4.8
	5/16	45.1		16.2			6.4
	3/8	45.9		16.9			7.1
12	1/4	47.0	22.8	15.3	4.8	22	
	5/16	47.8		16.2			6.4
	3/8	48.4		16.9			7.1
	1/2	51.2		22.9			9.5
14	1/2	52.0	24.4	22.9	10.3	24	
15	1/2	52.0	24.4	22.9	10.3	24	
16	5/8	52.0	24.4	24.4	12.7	24	
18	3/4	53.5	24.4	24.4	15.1	27	
20	1/2	55.0	26.0	22.9	10.3	30	
	1	62.8		31.3		35	
25	1	65.0	31.3	31.3	21.8	35	

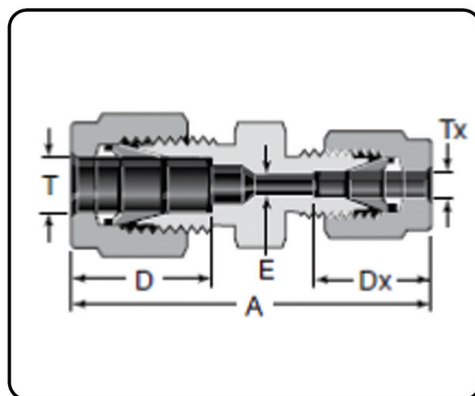

Tube OD in		Dimensions mm			
T	Tx	A	D	Dx	E
1/8	1/16	31.00	12.70	8.60	1.30
3/16	1/16	32.3	13.70	8.6	1.3
	1/8	36.6		12.7	2.3
1/4	1/16	34.3	15.20	8.6	1.3
	1/8	38.6		12.7	2.3
	3/16	39.4		13.7	3
5/16	1/8	39.6	16.30	12.7	2.3
	1/4	42.2		15.2	4.8
3/8	1/16	36.6	16.80	8.6	1.3
	1/8	40.9		12.7	2.3
	1/4	43.2		15.2	4.8
	5/16	44.2		16.3	6.4
1/2	1/8	45.2	22.90	12.7	2.3
	1/4	47		15.2	4.8
	3/8	48.5		16.8	7.1
5/8	3/8	49.3	24.40	16.8	7.1
	1/2	52.1		22.9	10.4
3/4	1/4	49.3	24.40	15.2	4.8
	3/8	50.8		16.8	7.1
	1/2	53.6		22.9	10.4
	5/8	53.6		24.4	12.7
1	1/2	60.50	31.20	22.9	10.4
	3/4			24.4	15.7

Tube OD		Dimensions mm			
T	Tx	A	D	Dx	E
3	2	35.3	12.9	12.9	1.7
6	2	38.6	15.3	12.9	1.7
	3	38.6		12.9	2.4
8	4	39.4	16.2	13.7	2.4
	6	42.3		15.3	4.8
10	6	44.5	17.2	15.3	4.8
	8	45.1		16.2	6.4
12	6	47.0	22.8	15.3	4.8
	8	47.8		16.2	6.4
	10	48.7		17.2	7.9
14	12	48.8	24.4	22.8	6.4
15	12	48.8	24.4	22.8	6.4
16	10	49.5	24.4	17.2	7.9
	12	52.0		22.8	9.5
18	12	53.5	24.4	22.8	9.5
25	18	61.0	31.3	24.4	15.1
	20	62.3		26.0	15.9
30	18	75.4	39.6	24.4	15.1
	20	75.4		26.0	15.9
	25	80.1		31.3	21.8
32	18	77.8	42.0	24.4	15.1
	20	77.8		26.0	15.9
	25	82.3		31.3	21.8
38	20	87.5	49.4	26.0	15.9
	25	92.0		31.3	21.8
	30	105		39.6	26.2



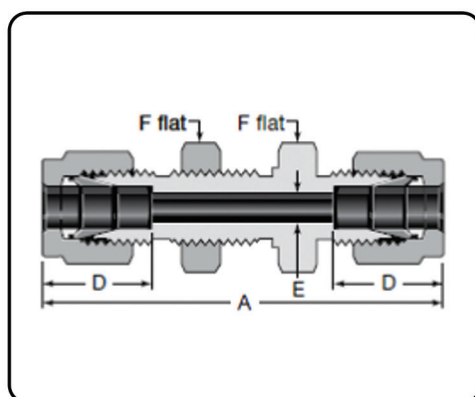

Tube OD in	Dimensions mm					
	A	D	E	F	Panel Hole Size	Max Panel Thickness
1/16	31.50	8.60	1.30	7.9	5.2	3
1/8	51.30	12.70	2.30	12.7	8.3	12.70
3/16	53.60	13.70	3.00	14.3	9.9	
1/4	57.70	15.20	4.80	15.9	11.5	10.20
5/16	60.70	16.30	6.40	17.5	13.1	11.20
3/8	62.20	16.80	7.10	19.1	14.7	
1/2	71.10	22.90	10.40	23.8	19.4	12.70
5/8	72.60	24.40	12.70	27	22.6	
3/4	79.00	24.40	15.70	30.2	25.8	16.80
1	95.80	31.20	22.40	41.3	33.7	19.10
1 1/4	123.20	41.10	27.70	47.6	41.7	
1 1/2	139.20	50.00	34.00	57.2	49.6	
2	180.30	67.60	46.00	69.9	67.1	

Tube OD	Dimensions mm					
	A	D	E	F	Panel Hole Size	Max Panel Thickness
3	51.3	12.9	2.4	14	8.3	12.7
4	53.6	13.7	2.4		9.9	
6	57.7	15.3	4.8	16	11.5	10.2
8	61.0	16.2	6.4	18	13.1	11.2
10	63.7	17.2	7.9	22	16.3	
12	71.0	22.8	9.5	24	19.5	12.7
14	72.5	24.4	11.1	27	22.5	
15	72.5	24.4	11.9		22.8	
16	72.5	24.4	12.7			
18	78.9	24.4	15.1	30	26.0	16.8
20	84.5	26.0	15.9	35	29.0	19.0
25	96.0	31.3	21.8	41	34.0	
30	124	39.6	26.2	50	40.5	
32	128	42.0	28.6		42.5	
38	145	49.4	33.7		60	

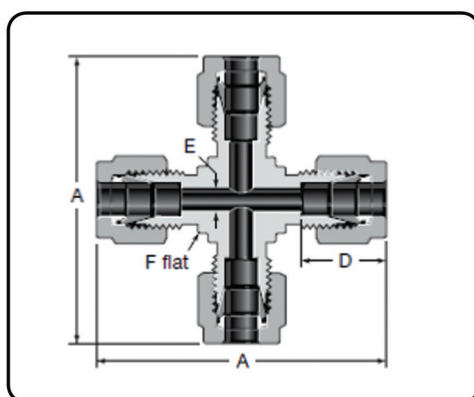

Tube OD in	Dimensions mm			
	A	D	E	F
1/8	44.70	12.70	2.30	9.5
1/4	53.80	15.20	4.80	12.7
5/16	59.40	16.30	6.40	15.9
3/8	61.00	16.80	7.10	15.9
1/2	72.10	22.90	10.40	20.6
3/4	79.80	24.40	15.70	27
1	98.00	31.20	22.40	34.9

Tube OD	Dimensions mm			
	A	D	E	F
3	44.7	12.9	2.4	9.5
6	53.9	15.3	4.8	12.7
8	59.7	16.2	6.4	15.9
10	67.0	17.2	7.9	20.6
12	72.0	22.8	9.5	20.6
16	74.0	24.4	12.7	23.8
18	76.6	24.4	15.1	27
20	89.3	26.0	15.9	34.9
22	89.4	26.0	18.3	15.9
25	98.3	31.3	21.8	34.9



Follow us at :



For more details, Contact at :

- +91 9930568025
- sales@maffsvalves.com
- www.maffsvalves.com

CORPORATE & FACTORY :

Gala No. 9, Building No. 3, Patel Industrial Estate, Gokhivare,
Range Office, Vasai East, Palghar - 401208

